

Dreikantleiste nicht eingezeichnet(23)

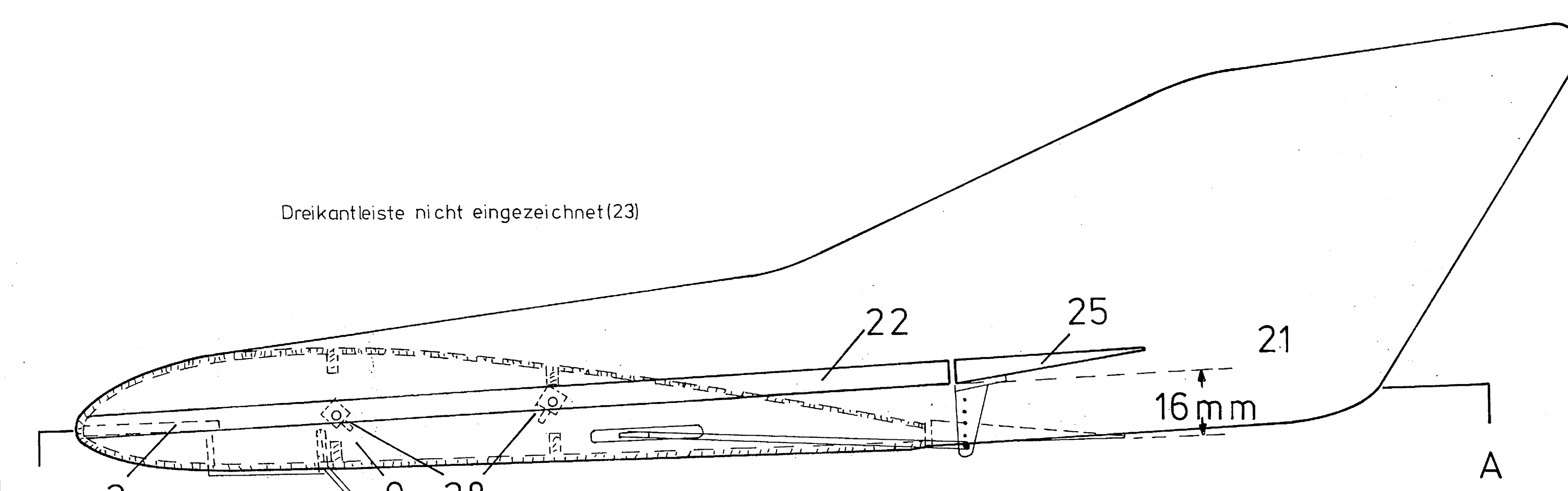

Schnitt A - A

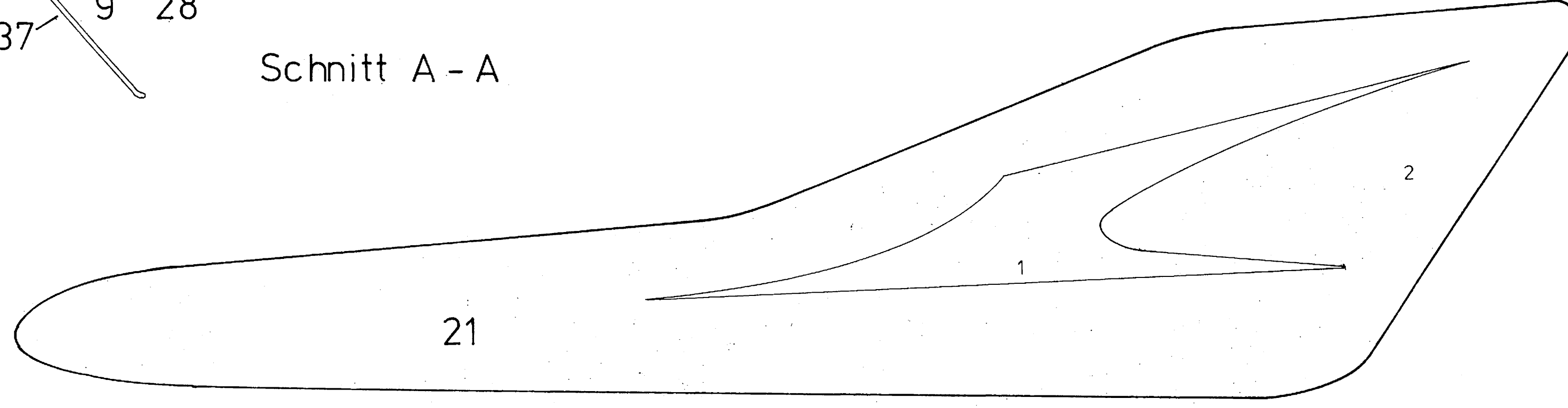

Schnitt B - B

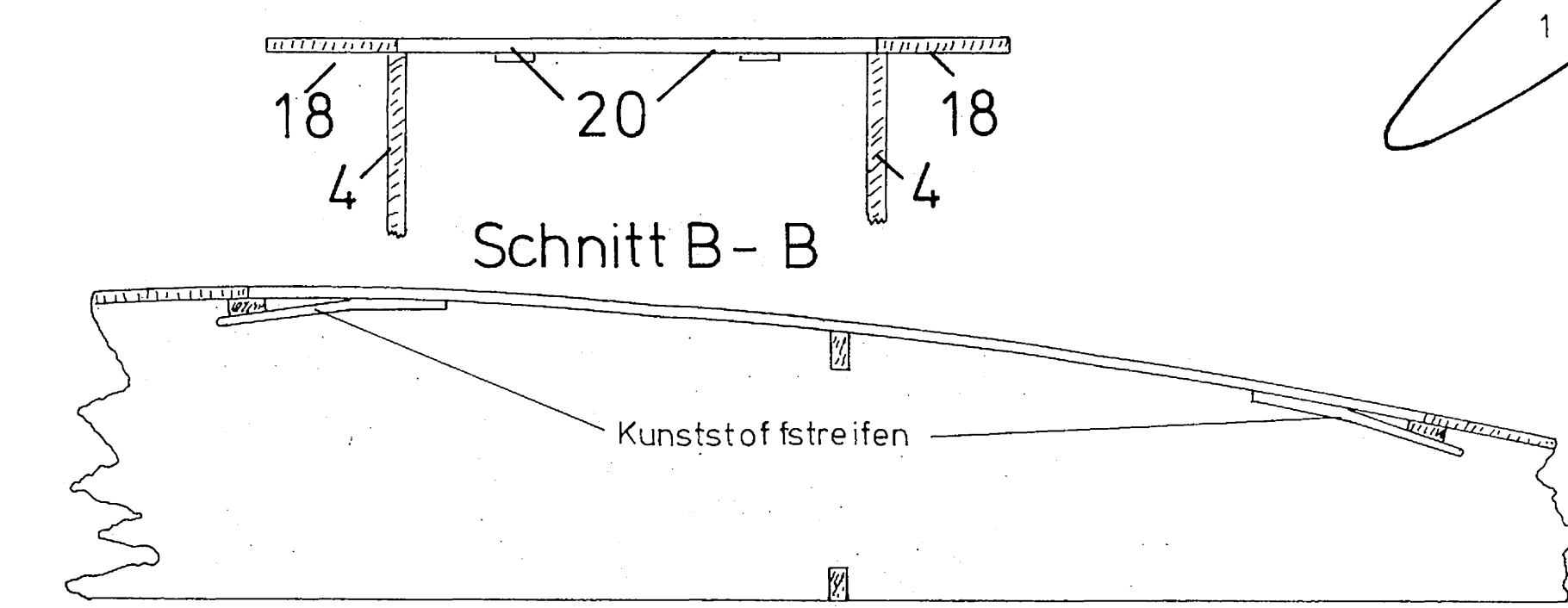

Schnitt C - C

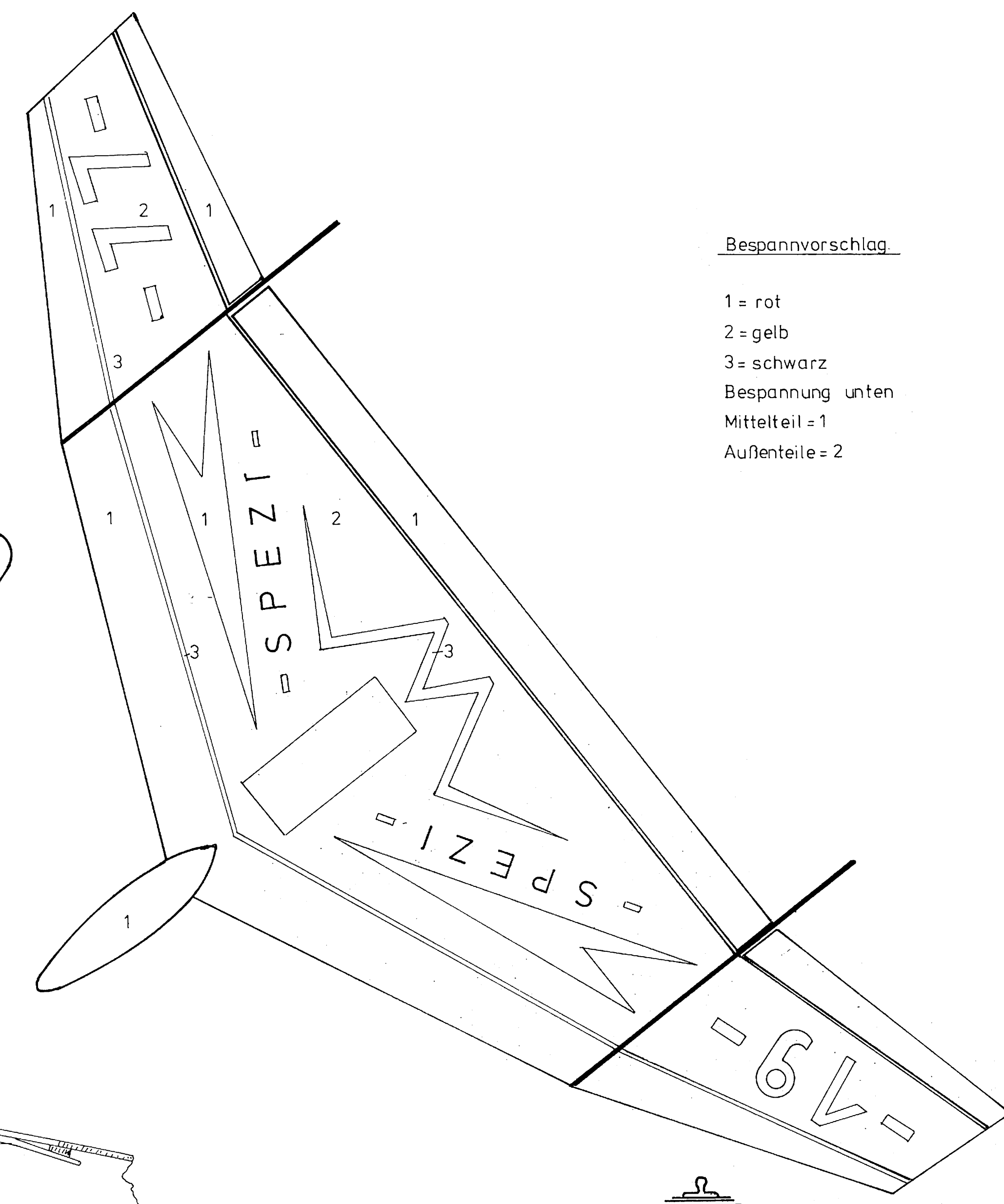

- Bespannvorschlag
- 1 = rot
  - 2 = gelb
  - 3 = schwarz
- Bespannung unten  
Mittelteil = 1  
Außenteile = 2

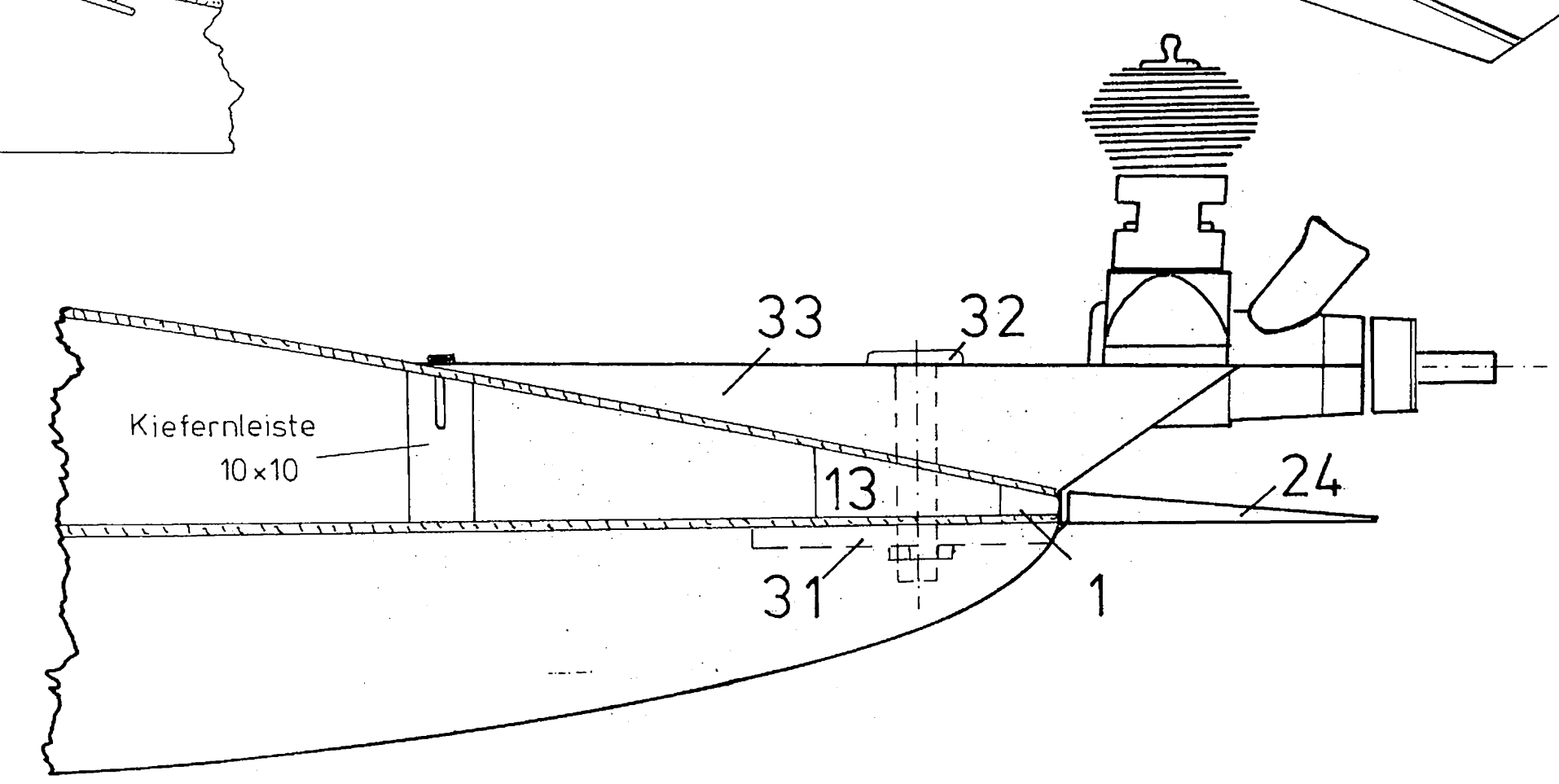
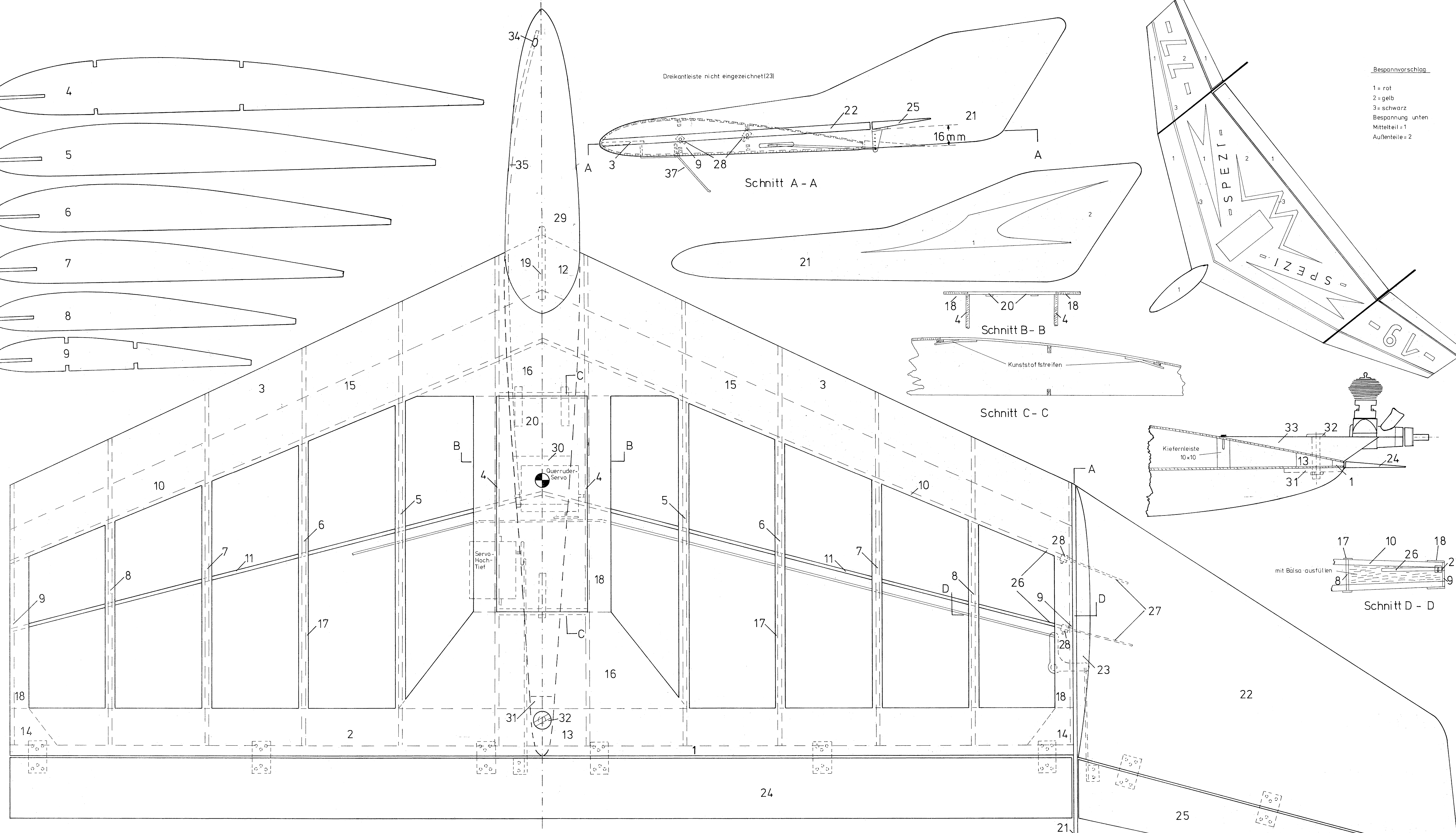

Schnitt D - D

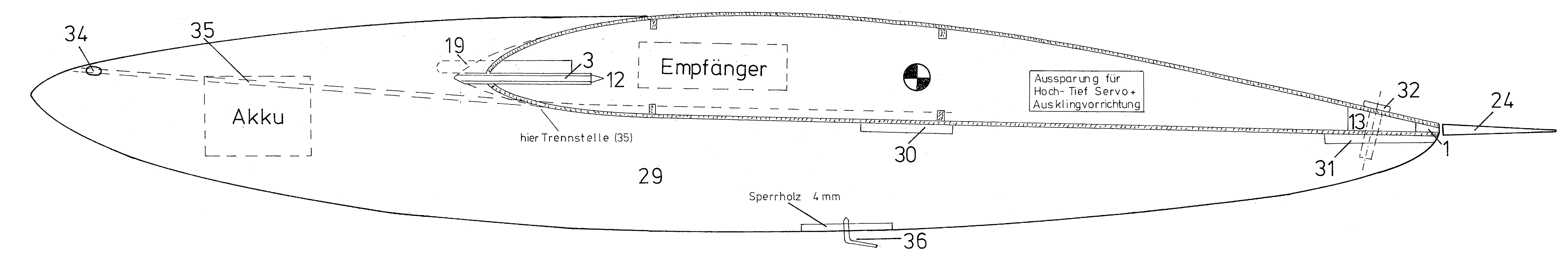
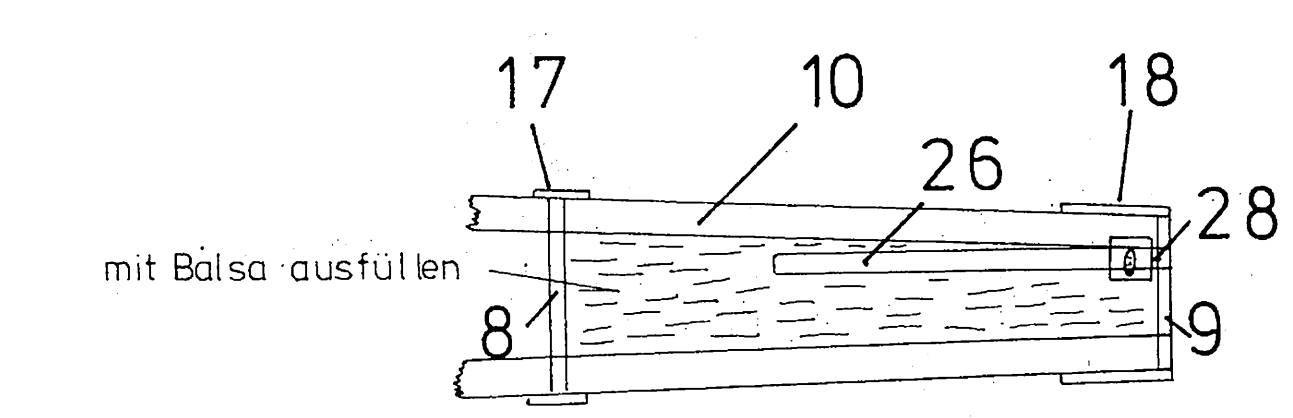

# SPEZI

Universal - RC-Nurflügelmodell  
für Hang-Thermik-Schlepp-  
und Motorkunstflug  
von Lothar Wehmann 4804 Versmold

Maßstab: 1:1  
Spannweite: ca. 1530 mm  
Gesamtlänge: ca. 790 mm  
Flächeninhalt: ca. 4740 qdm  
Motor: ca. 1,5ccm  
Gewicht mit Motor: ca. 1050g

Gewerbliche Nutzung nicht gestattet



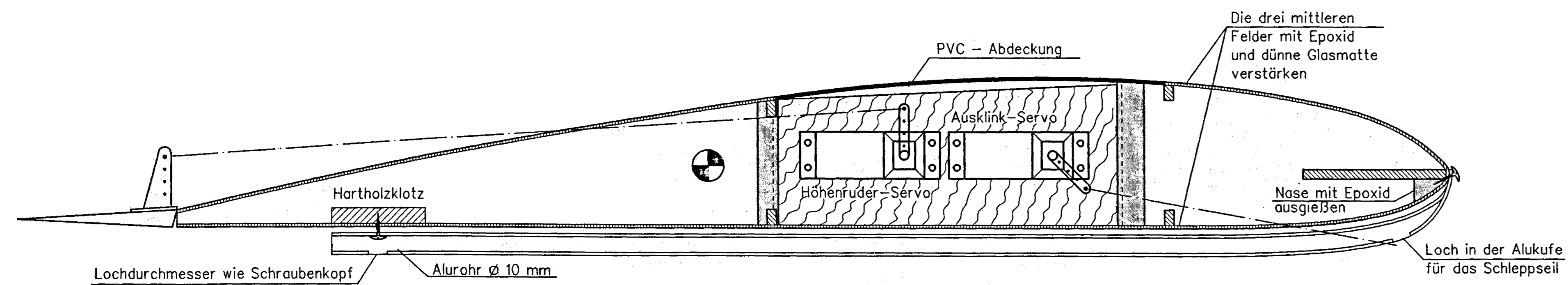

SCHNITT B - B

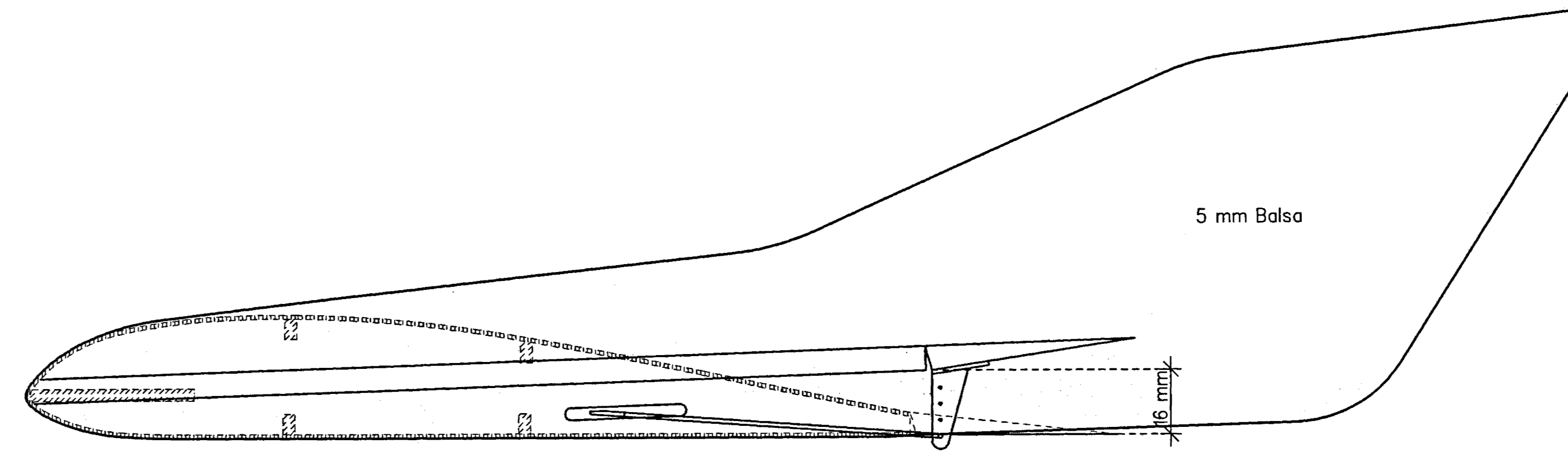

SCHNITT A - A

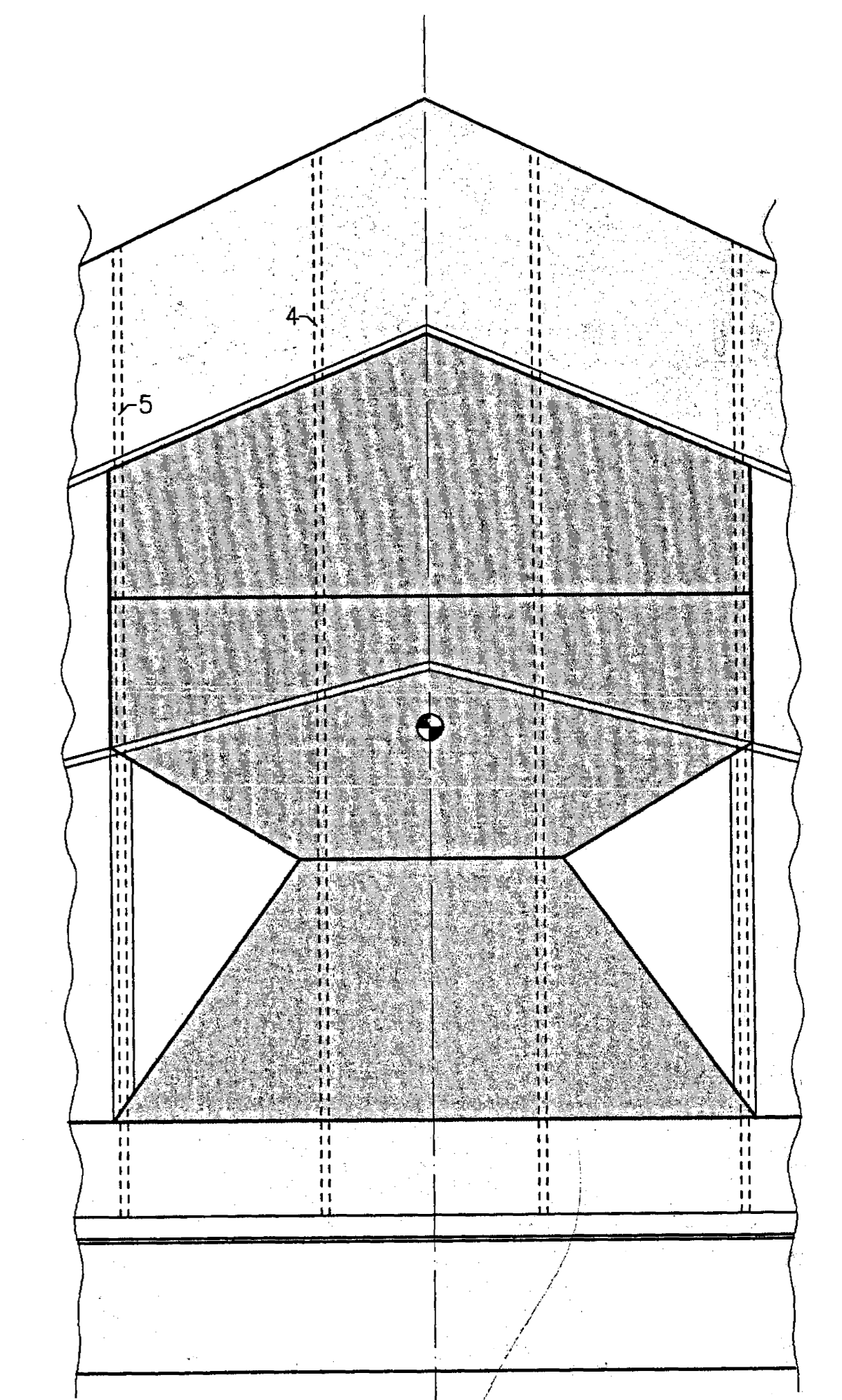

UNTERE BEPLANKUNG

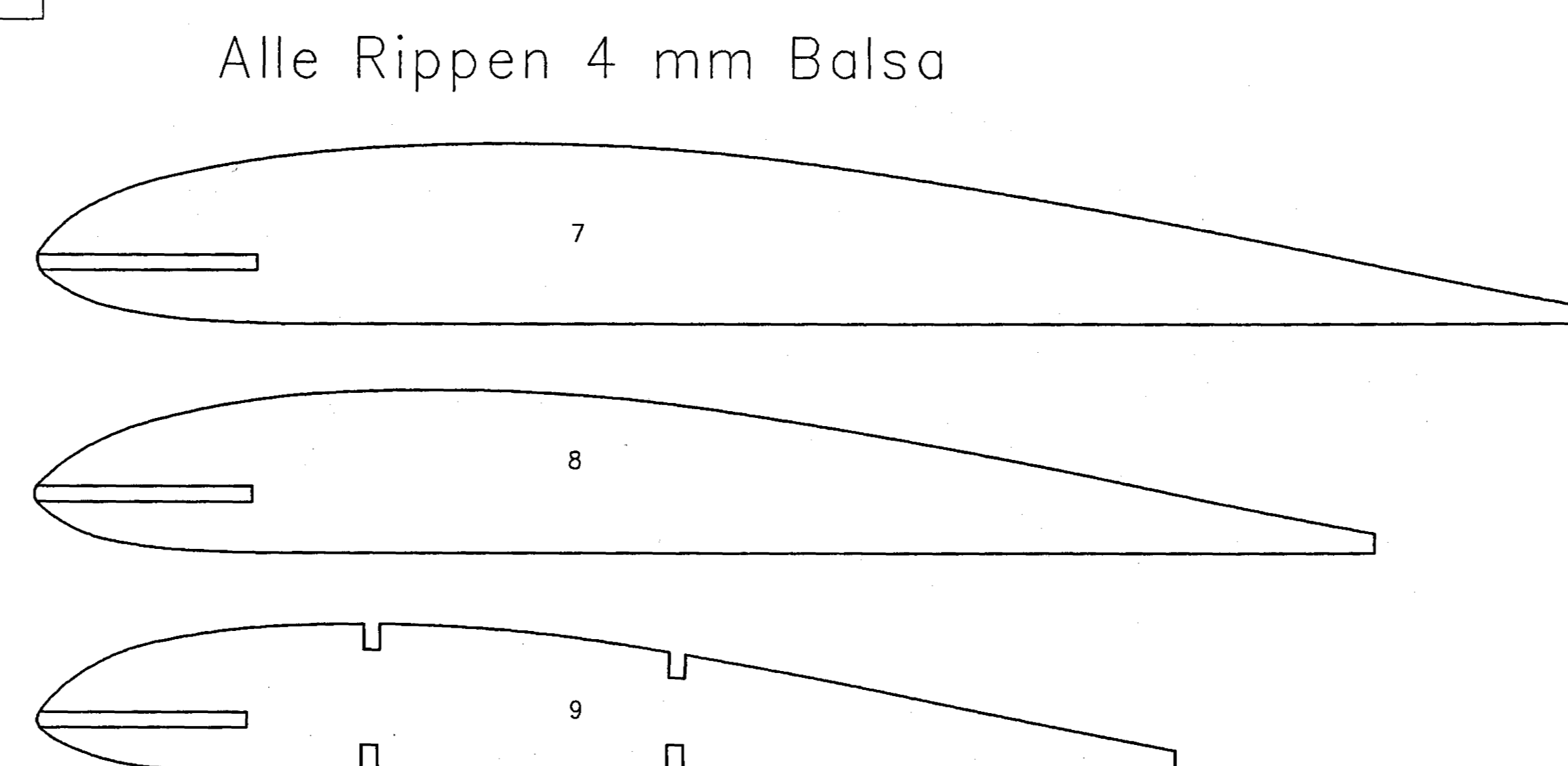
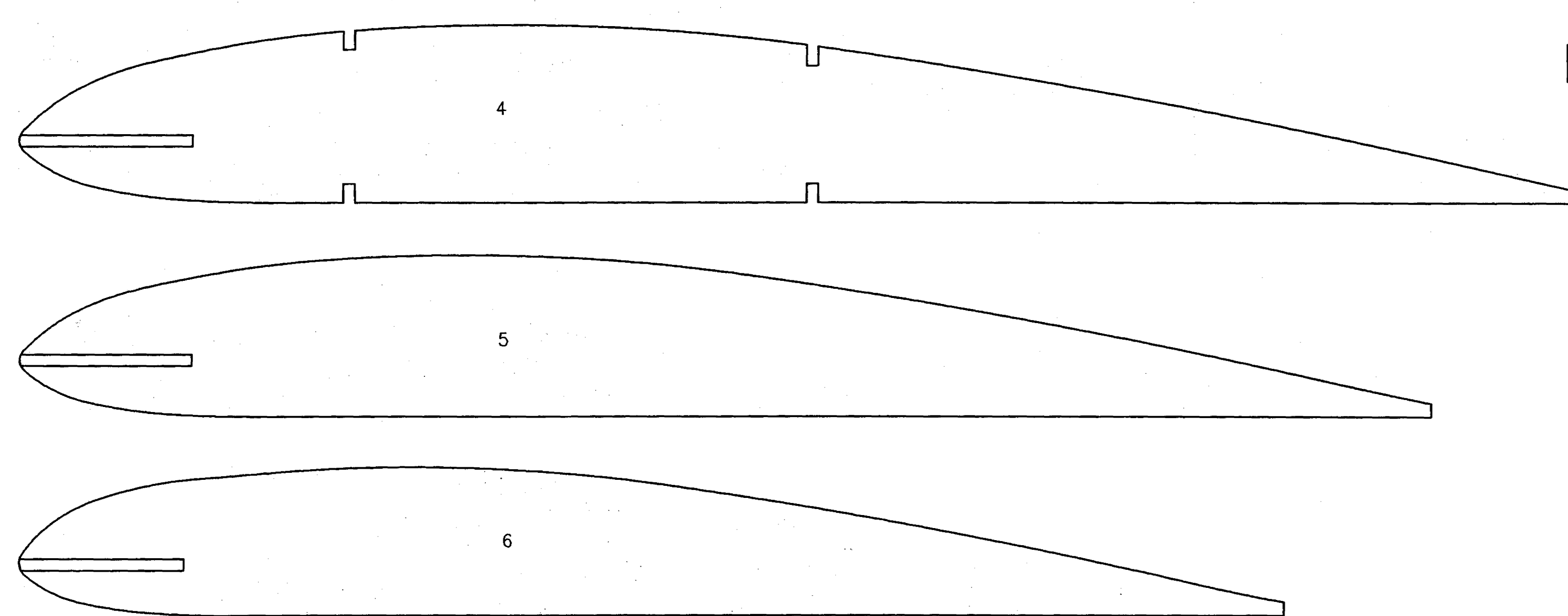
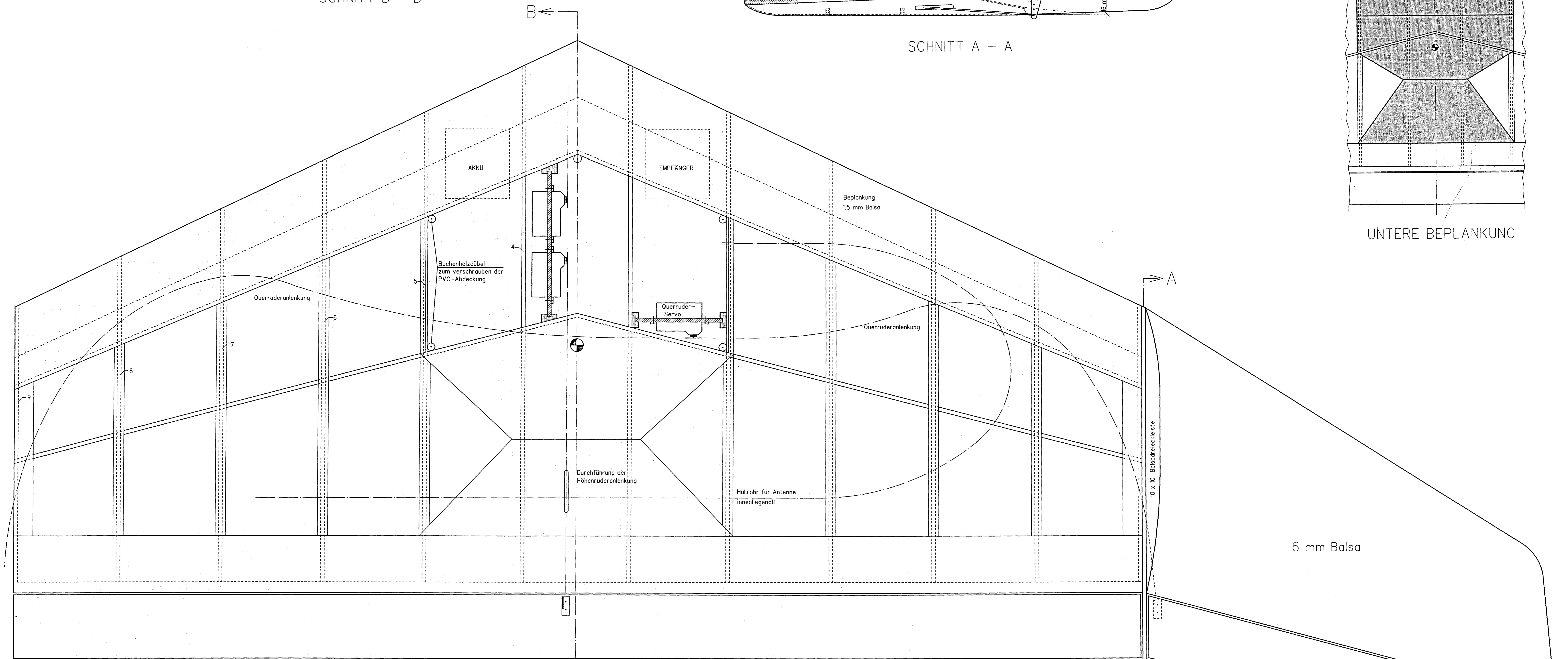

Alle Rippen 4 mm Balsa

<b>SPEZI</b>		Spannweite:	1520 mm
NURFLÜGELMODELL FÜR DEN HANGFLUG SOWIE FÜR SCHLEPP- UND TERMIFLUG		Gesamtlänge:	620 mm
		Gewicht:	ca. 950 g
Modellbau Tel.: 0591 / 48086		Moßstab:	1:1

